

REPLACEMENT TYPE : PBSS5350T

FEATURES

- High collector current capability
- High collector current gain
- Improved efficiency due to reduced heat generation.
- Low collector-emitter saturation voltage V_{CEsat} and corresponding low R_{CEsat}

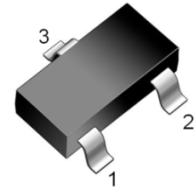

SOT-23 MARKING:ZD

1: BASE 2: EMITTER 3: COLLECTOR

MAXIMUM RATINGS ($T_A = 25^\circ\text{C}$ unless otherwise noted)

Parameter	Symbol	Value				Unit
Collector-Base Voltage	V_{CBO}	-50				V
Collector-Emitter Voltage	V_{CEO}	-50				V
Emitter-Base Voltage	V_{EBO}	-5				V
Collector Current-Continuous	I_C	-2				A
Repetitive Peak Collector Current (Note.1)	I_{CRP}	-3				A
Collector Current - Pulse	I_{CP}	-5				A
Base Current	I_B	-0.5				A
Collector Power Dissipation	P_C	300 ^{Note2}	480 ^{Note3}	540 ^{Note4}	1.2 ^{Note1,2}	mW
Junction Temperature	T_J	150				$^\circ\text{C}$
Storage Temperature	T_{stg}	-65 to 150				$^\circ\text{C}$
Operating Ambient Temperature	T_{amb}	-65 to 150				$^\circ\text{C}$

Notes:

1. Operated under pulsed conditions: pulse width $t_p \leq 100$ ms; duty cycle $\delta \leq 0.25$.
2. Device mounted on a printed-circuit board; single sided copper; tinplated; standard footprint.
3. Device mounted on a printed-circuit board; single sided copper; tinplated; mounting pad for collector 1 cm^2 .
4. Device mounted on a printed-circuit board; single sided copper; tinplated; mounting pad for collector 6 cm^2 .

ELECTRICAL CHARACTERISTICS ($T_A=25^{\circ}\text{C}$ unless otherwise noted)

Parameter	Symbol	Test Conditions	Min	Typ.	Max.	Unit
Collector- Base Breakdown Voltage	V_{CBO}	$I_C = -100\mu\text{A}$, $I_E = 0$	-50			v
Collector- Emitter Breakdown Voltage	V_{CEO}	$I_C = -1\text{mA}$, $I_B = 0$	-50			v
Emitter - Base Breakdown Voltage	V_{EBO}	$I_E = -100\mu\text{A}$, $I_C = 0$	-50			v
collector-Base Cut-off Current	I_{CBO}	$V_{CB} = -50\text{V}$; $I_E = 0$			-100	nA
		$V_{CB} = -50\text{V}$; $I_E = 0$; $T_j = 150^{\circ}\text{C}$			-50	μA
emitter-Base Cut-off Current	I_{EBO}	$V_{EB} = -5\text{V}$; $I_C = 0$			-100	nA
DC Current Gain	h_{FE}	$V_{CE} = -2\text{V}$; $I_C = -100\text{mA}$	200			
		$V_{CE} = -2\text{V}$; $I_C = -500\text{mA}$	200			
		$V_{CE} = -2\text{V}$; $I_C = -1\text{A}$; note 1	200			
		$V_{CE} = -2\text{V}$; $I_C = -2\text{A}$; note 1	130			
		$V_{CE} = -2\text{V}$; $I_C = -3\text{A}$; note 1	80			
Collector-Emitter Saturation Voltage	$V_{CE(sat)}$	$I_C = -500\text{mA}$; $I_B = -50\text{mA}$			-90	mV
		$I_C = -1\text{A}$; $I_B = -50\text{mA}$			-180	mV
		$I_C = -2\text{A}$; $I_B = -100\text{mA}$; note 1			-320	mV
		$I_C = -2\text{A}$; $I_B = -200\text{mA}$; note 1			-270	mV
		$I_C = -3\text{A}$; $I_B = -300\text{mA}$; note 1			-390	mV
Equivalent on-Resistance	$R_{CE(sat)}$	$I_C = -2\text{A}$; $I_B = -200\text{mA}$; note 1		90	135	$\text{m}\Omega$
Base-Emitter Saturation Voltage	$V_{BE(sat)}$	$I_C = -2\text{A}$; $I_B = -100\text{mA}$; note 1			-1.1	V
		$I_C = -3\text{A}$; $I_B = -300\text{mA}$; note 1			-1.2	V
Base-Emitter Turn-on Voltage	$V_{BE(on)}$	$V_{CE} = -2\text{V}$; $I_C = -1\text{A}$; note 1	-1.2			V
Transition Frequency	f_T	$I_C = -100\text{mA}$; $V_{CE} = -5\text{V}$; $f = 100\text{MHz}$	100			MHz
Collector Capacitance	C_c	$V_{CB} = -10\text{V}$; $I_E = I_C = 0$; $f = 1\text{MHz}$			35	pF

 Note 1. Pulse test: $t_p \leq 300\mu\text{s}$; $\delta \leq 0.02$.

Typical Characteristics

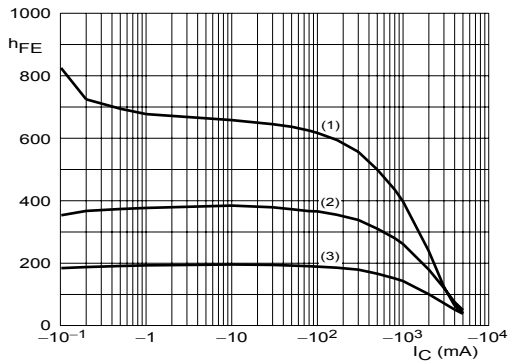

$V_{CE} = -2 V.$
(1) $T_{amb} = 150\text{ }^{\circ}C.$
(2) $T_{amb} = 25\text{ }^{\circ}C.$
(3) $T_{amb} = -55\text{ }^{\circ}C.$

Fig.1 DC current gain as a function of collector current; typical values.

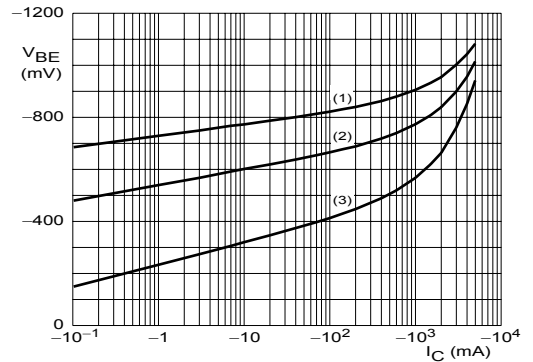

$V_{CE} = -2 V.$
(1) $T_{amb} = -55\text{ }^{\circ}C.$
(2) $T_{amb} = 25\text{ }^{\circ}C.$
(3) $T_{amb} = 150\text{ }^{\circ}C.$

Fig.2 Base-emitter voltage as a function of collector current; typical values.

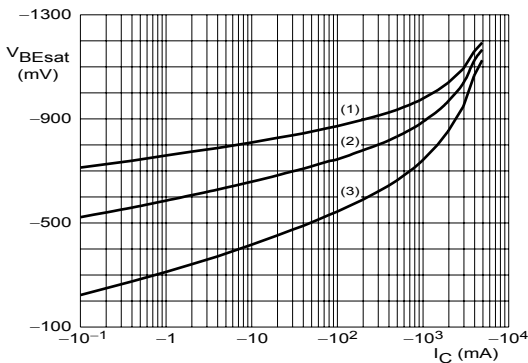

$I_C/I_B = 10.$
(1) $T_{amb} = -55\text{ }^{\circ}C.$
(2) $T_{amb} = 25\text{ }^{\circ}C.$
(3) $T_{amb} = 150\text{ }^{\circ}C.$

Fig.3 Base-emitter saturation voltage as a function of collector current; typical values.

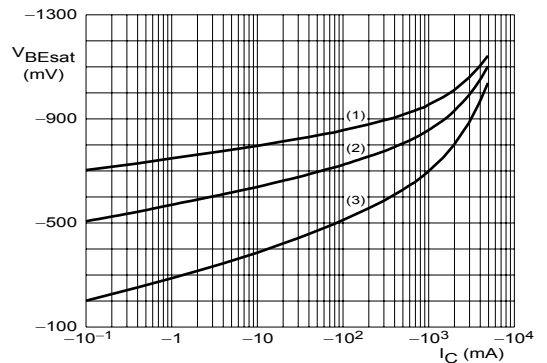

$I_C/I_B = 20.$
(1) $T_{amb} = -55\text{ }^{\circ}C.$
(2) $T_{amb} = 25\text{ }^{\circ}C.$
(3) $T_{amb} = 150\text{ }^{\circ}C.$

Fig.4 Base-emitter saturation voltage as a function of collector current; typical values.

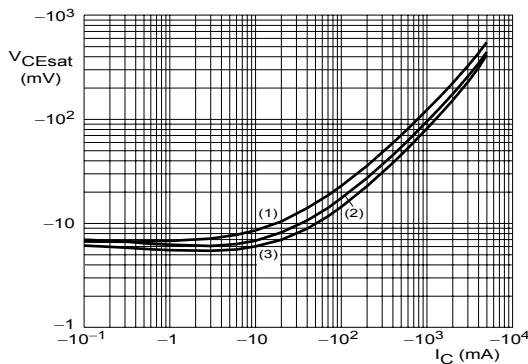

$I_C/I_B = 10.$
(1) $T_{amb} = 150\text{ }^{\circ}C.$
(2) $T_{amb} = 25\text{ }^{\circ}C.$
(3) $T_{amb} = -55\text{ }^{\circ}C.$

Fig.5 Collector-emitter saturation voltage as a function of collector current; typical values.

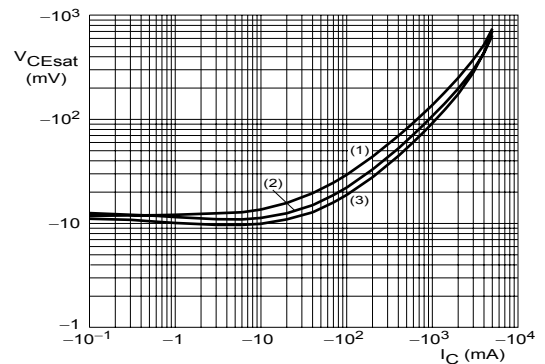

$I_C/I_B = 20.$
(1) $T_{amb} = 150\text{ }^{\circ}C.$
(2) $T_{amb} = 25\text{ }^{\circ}C.$
(3) $T_{amb} = -55\text{ }^{\circ}C.$

Fig.6 Collector-emitter saturation voltage as a function of collector current; typical values.

Typical Characteristics

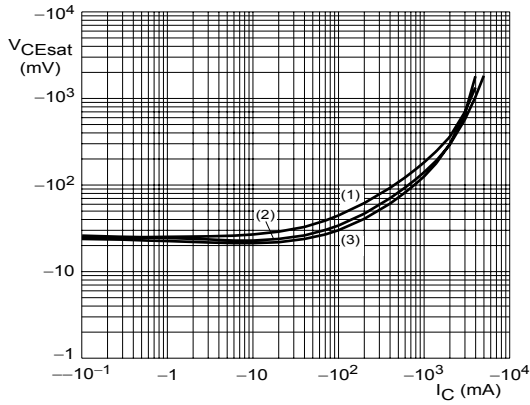

$I_C/I_B = 50$.
 (1) $T_{amb} = 150\text{ }^{\circ}\text{C}$.
 (2) $T_{amb} = 25\text{ }^{\circ}\text{C}$.
 (3) $T_{amb} = -55\text{ }^{\circ}\text{C}$.

Fig.7 Collector-emitter saturation voltage as a function of collector current; typical values.

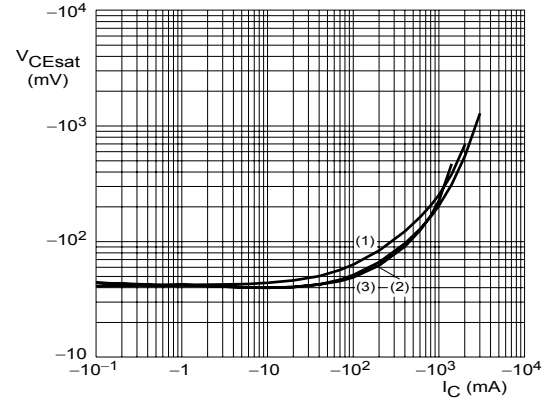

$I_C/I_B = 100$.
 (1) $T_{amb} = 150\text{ }^{\circ}\text{C}$.
 (2) $T_{amb} = 25\text{ }^{\circ}\text{C}$.
 (3) $T_{amb} = -55\text{ }^{\circ}\text{C}$.

Fig.7 Collector-emitter saturation voltage as a function of collector current; typical values.

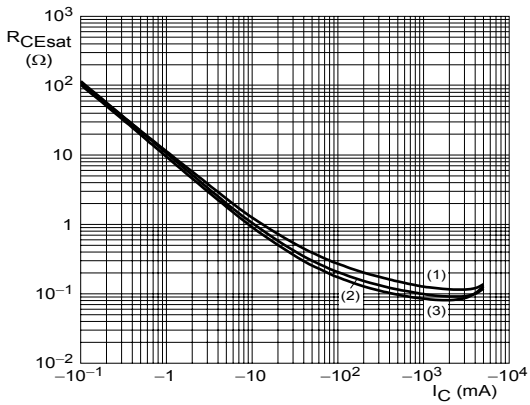

$I_C/I_B = 20$.
 (1) $T_{amb} = 150\text{ }^{\circ}\text{C}$.
 (2) $T_{amb} = 25\text{ }^{\circ}\text{C}$.
 (3) $T_{amb} = -55\text{ }^{\circ}\text{C}$.

Fig.9 Equivalent on-resistance as a function of collector current; typical values.

SOT-23 Package Outline Dimensions

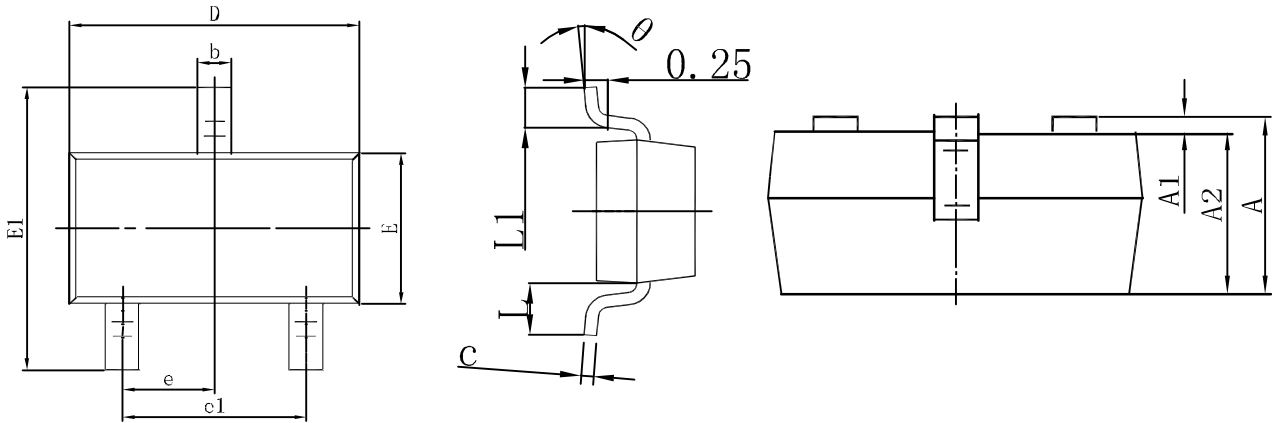

Symbol	Dimensions In Millimeters		Dimensions In Inches	
	Min.	Max.	Min.	Max.
A	0.900	1.150	0.035	0.045
A1	0.000	0.100	0.000	0.004
A2	0.900	1.050	0.035	0.041
b	0.300	0.500	0.012	0.020
c	0.080	0.150	0.003	0.006
D	2.800	3.000	0.110	0.118
E	1.200	1.400	0.047	0.055
E1	2.250	2.550	0.089	0.100
e	0.950 TYP		0.037 TYP	
e1	1.800	2.000	0.071	0.079
L	0.550 REF		0.022 REF	
L1	0.300	0.500	0.012	0.020
θ	0°	8°	0°	8°

SOT-23 Embossed Carrier Tape

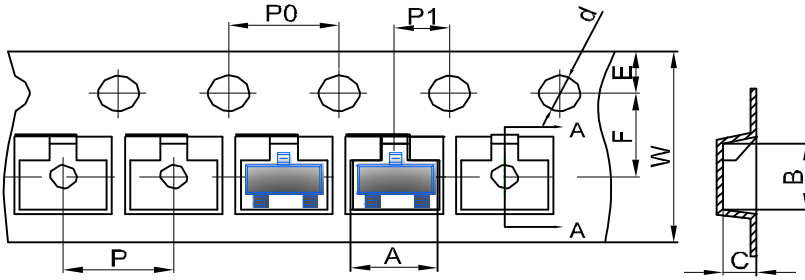

DIMENSIONS ARE IN MILLIMETER										
TYPE	A	B	C	d	E	F	P0	P	P1	W
SOT-23	3.15	2.77	1.22	φ1.50	1.75	3.50	4.00	4.00	2.00	8.00
TOLERANCE	±0.1	±0.1	±0.1	±0.1	±0.1	±0.1	±0.1	±0.1	±0.1	±0.1

SOT-23 Tape Leader and Traller

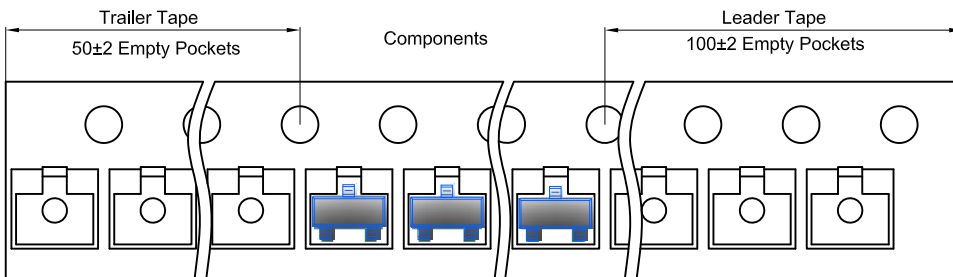

SOT-23 Reel

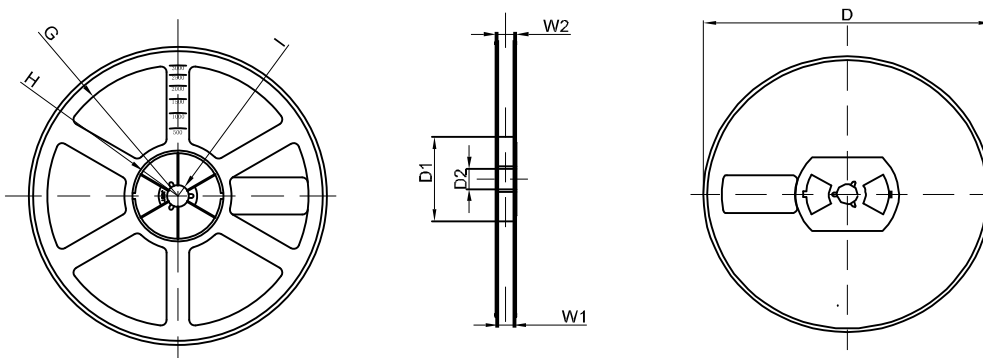

DIMENSIONS ARE IN MILLIMETER								
REEL OPTION	D	D1	D2	G	H	I	W1	W2
7" DIA	φ178	54.40	13.00	R78	R25.60	R6.50	9.50	12.30
TOLERANCE	±2	±1	±1	±1	±1	±1	±1	±1