

DESCRIPTION

VLA546 is a hybrid integrated circuit designed for driving n-channel IGBT modules in any gate-amplifier application. This device operates as an isolation amplifier for these modules and provides the required electrical isolation between the input and output with an opto-coupler.

Recommended IGBT modules:

V_{CES} = 600V series up to 600A class

V_{CES} = 1200V series up to 400A class

V_{CES} = 1700V series up to 400A class

FEATURES

- Electrical isolation between input and output with opto-coupler
(Viso = 4000Vrms for 1minute)
- Two supply driver topology
- Built-in short circuit protection circuit(With a pin for fault out)
- Variable fall time on activity of short circuit protection.
- TTL compatible input interface

OUTLINE DRAWING

Dimensions : mm

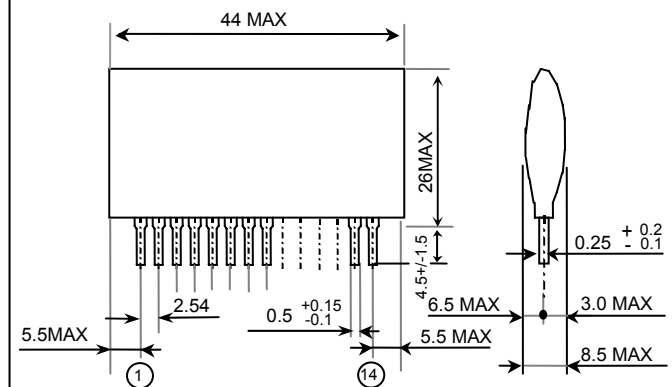

APPLICATIONS

To drive IGBT modules for inverter or AC servo systems application

BLOCK DIAGRAM

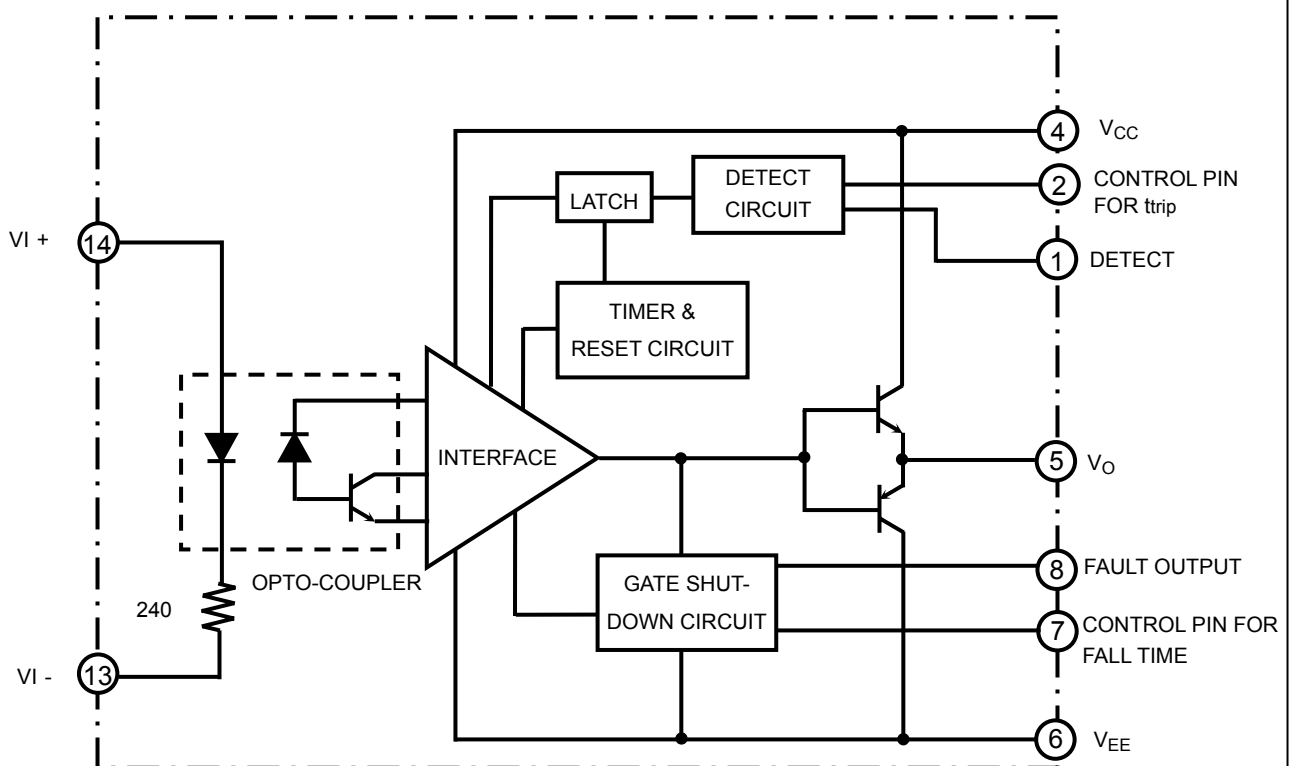

3 pin : Non connection

MAXIMUM RATINGS (unless otherwise noted, $T_a=25^\circ\text{C}$)

Symbol	Parameter	Conditions	Ratings	Unit
V_{CC}	Supply voltage	DC	18	V
V_{EE}			-15	V
V_i	Input signal voltage	Applied between; 13pin and 14pin 50% duty cycle, pulse width 1ms	-1 ~ +7	V
V_O	Output voltage	When the output voltage is "H"	V_{CC}	V
I_{OHP}	Output peak current	Pulse width 2us	-5	A
I_{OLP}			5	A
Viso	Isolation voltage	Sine wave voltage 60Hz, for 1minute	4000	Vrms
T_C	Case temperature	-	95	$^\circ\text{C}$
T_{opr}	Operating temperature	No condensation allowable	-20 ~ +85	$^\circ\text{C}$
T_{stg}	Storage temperature	No condensation allowable	-40 ~ +100 (*1)	$^\circ\text{C}$
I_{FO}	Fault output current	Applied 8pin	20	mA
V_{R1}	Input voltage at 1pin	-	50	V

(*1) Differs from H/C condition

ELECTRICAL CHARACTERISTICS (unless otherwise noted, $T_a=25^\circ\text{C}$, $V_{CC} = 15\text{V}$, $V_{EE} = -10\text{V}$, $R_G = 3$)

Symbol	Parameter	Conditions	Limits			Unit
			Min	Typ	Max	
V_{CC}	Supply voltage	Recommended range	14	15	17	V
V_{EE}			-7	-	-12	V
V_{IN}	Pull-up voltage on primary side	Recommended range	4.75	5	5.25	V
I_{IH}	"H" input signal current	Recommended range	10	13	16	mA
f	Switching frequency	Recommended range	-	-	20	kHz
R_G	Gate resistance	Recommended range	2	-	-	
I_{IH}	"H" input signal current	$V_{IN} = 5\text{V}$ HC04drive	-	13	-	mA
V_{OH}	"H" output voltage	-	13	14	-	V
V_{OL}	"L" output voltage	-	-8	-9	-	V
t_{PLH}	"L-H" propagation time	$I_{IH}=13\text{mA}$	0.2	0.4	1	μs
t_r	"L-H" rise time	$I_{IH}=13\text{mA}$	-	0.3	1	μs
t_{PHL}	"H-L" propagation time	$I_{IH}=13\text{mA}$	0.2	0.4	1	μs
t_f	"H-L" fall time	$I_{IH}=13\text{mA}$	-	0.3	1	μs
t _{timer}	Timer	Between start and cancel (under input signal "L")	1	-	2	ms
I_{FO}	Fault output current	Applied 8pin, $R = 4.7\text{k ohm}$	-	5	-	mA
t_{trip1}	Controlled time detect short circuit 1	Pin1: 15V and more, Pin2:open	-	2.6	-	μs
t_{trip2}	Controlled time detect short circuit 2 (*2)	Pin1: 15V and more, Pin2-4:10pF (connective capacitance)	-	3	-	μs
V_{SC}	SC detect voltage	-	15	-	-	V

(*2) Length of wiring of capacitor controlled time detect short-circuit is within 5cm from pin2 and pin4 coming and going.

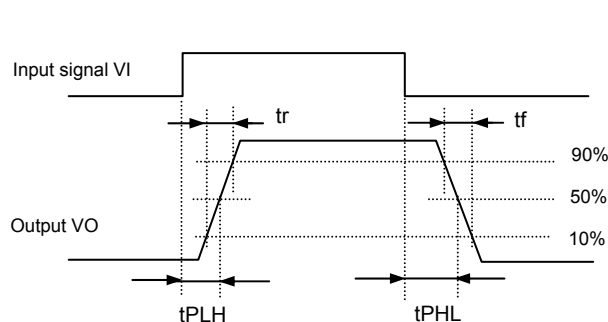
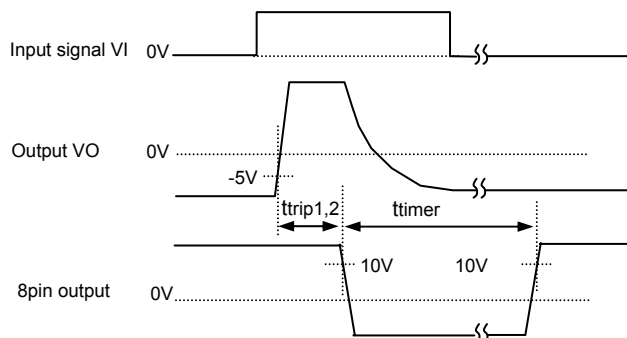
DEFINITION OF CHARACTERISTICS**(1) SWITCHING OPERATION****(2) SHORT CIRCUIT PROTECTION**

• PERFORMANCE CURVES

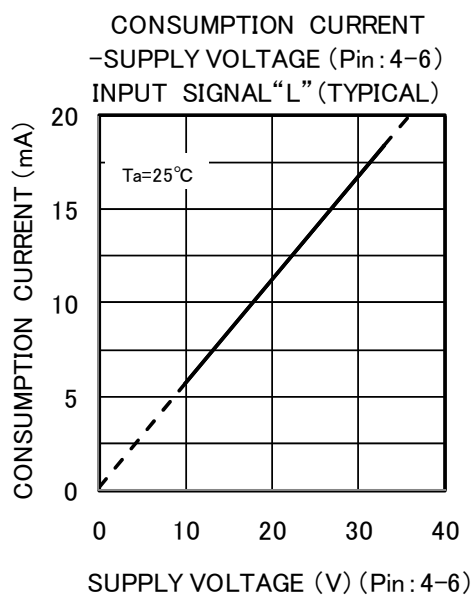
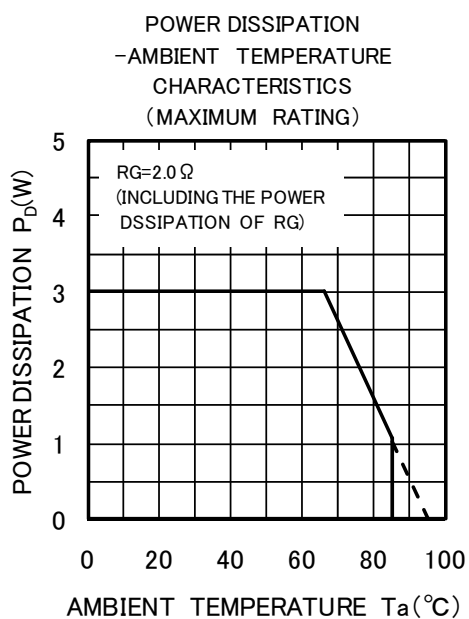
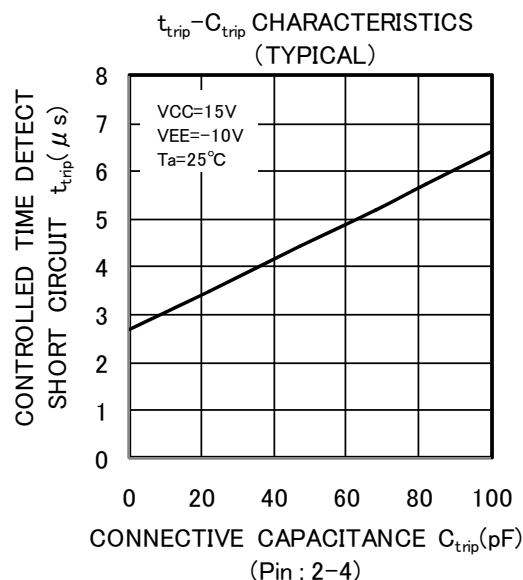
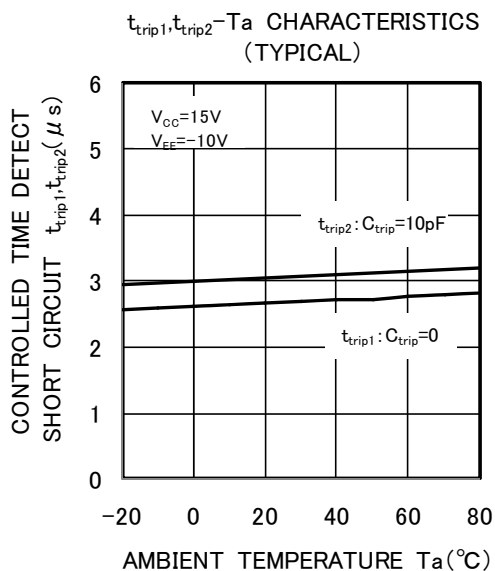
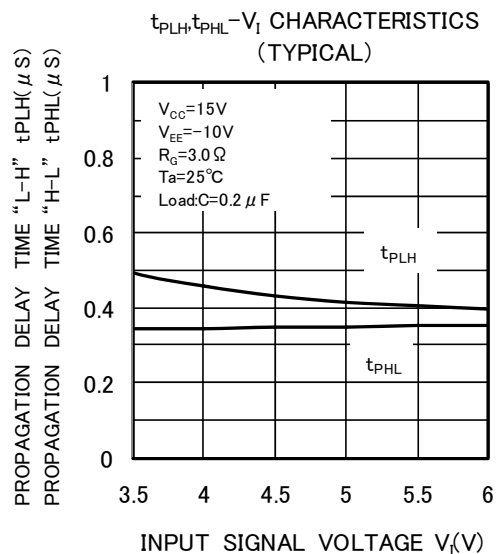
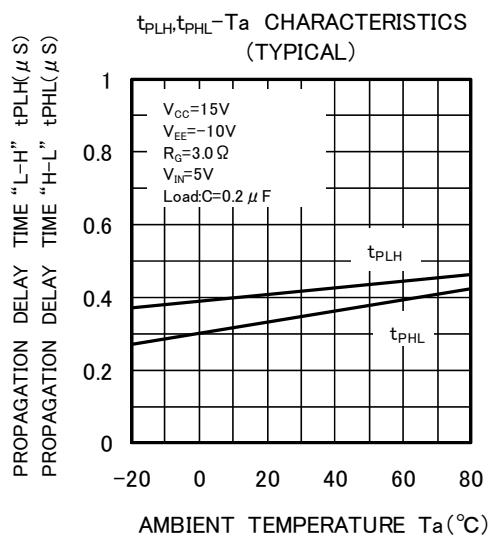

OPERATION OF PROTECTION CIRCUIT

- (1) In case the gate voltage is "H" and the collector voltage is high, this hybrid IC will recognize the circuit as short circuit and immediately reduce the gate voltage. Besides, put out an error signal ("L") which inform that protection circuit is operating at the same time from pin8.
- (2) The protection circuit reset and resort to ordinary condition if input signal is "L" when the premised 1~2msec passed. ("L" period needs 10us or more with pin7 open)
- (3) When the output rises, the controlled time detect short circuit (Typ 2.6us) is set up so that on-time of IGBT can be secured properly. It is possible to adjust that time by connecting the capacitor (Ctrip) between pin2 and 4.

• ADJUSTMENT OF OUTPUT FALL TIME

(When the protection circuit is operating)

In case you want to decrease the speed of reverse bias when the protection circuit is operating , you can adjust that speed by connecting the capacitor (Cs) between pin6 and pin7.(Refer to under figures)

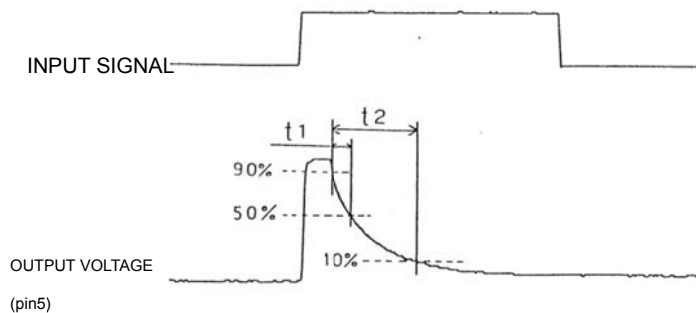

OPERATION FLOW ON DETECTING SHORTCIRCUIT

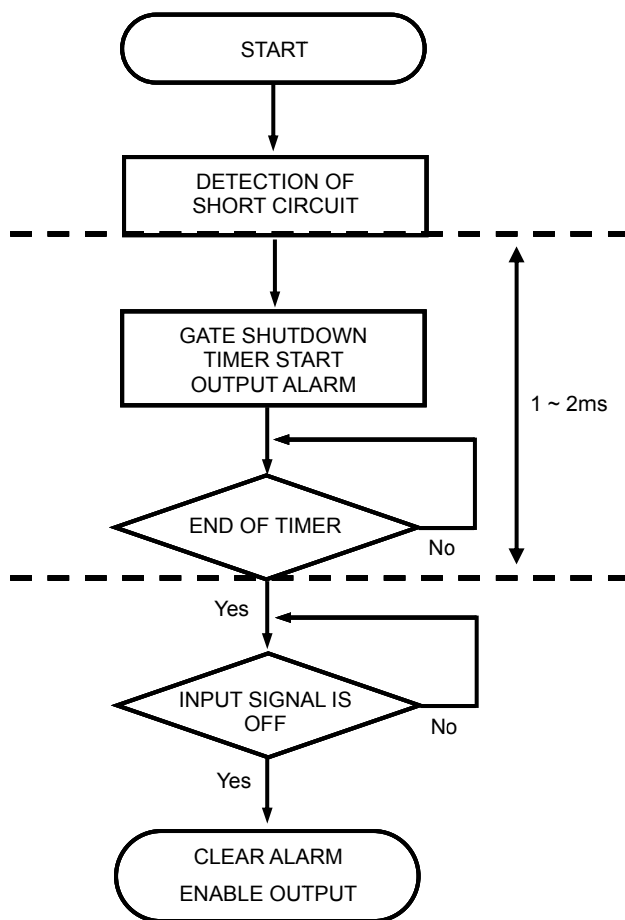

t₁,t₂ VS,C_s CHARACTERISTICS (TYPICAL)

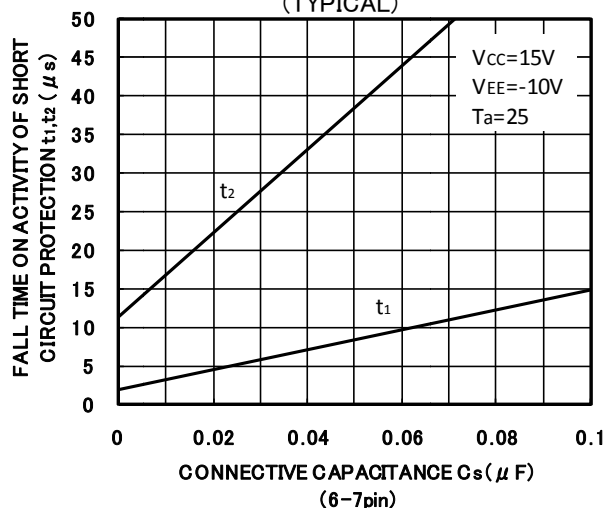

(*) Output voltage with protection circuit operating is about -|VEE|+2V

APPLICATION CIRCUIT EXAMPLE

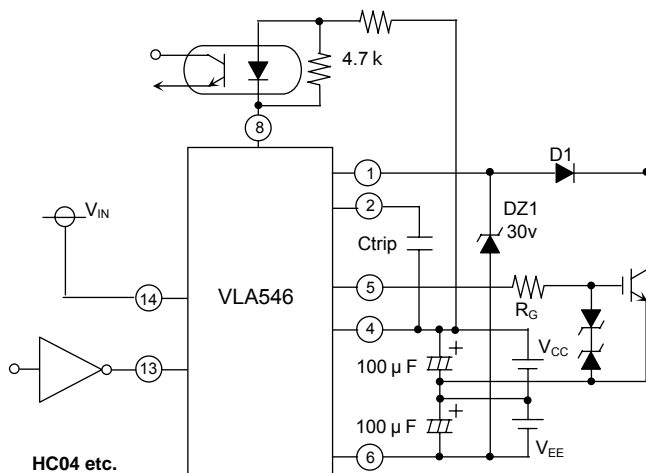

HC04 etc.

f=20kHz

D.F.=50%

VIN=5V

 $V_{CC} = 15V$ $V_{EE} = 10V$

RG=3

Ctrip = 0 ~ 47pF(Rough guide)

D1: Fast recovery diode (trr ≤ 0.2us)

RP1H (SanKen) etc.

PRECAUTION

- (1) Voltage compensate capacitors are expected to be located as close as possible from the hybrid IC.
- (2) D1 requires approximately the same voltage of power modules.
- (3) If reverse recovery time of D1 is long, pin1 is applied high voltage. In that case, counterplan for protection which insert a zener diode between pin 1 and 6 is necessary like above diagram.
- (4) In case pin 2 is operating, the Ctrip is expected to be wired as close as possible from pin 2 and pin 4.
(Less than 5cm coming and going)

APPLICATION EXAMPLE OF SINGLE POWER SUPPLY

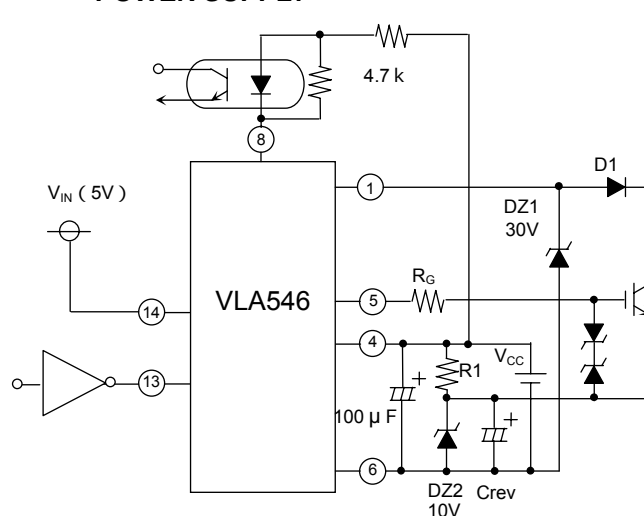
 $V_{CC} = 25V$

Crev=100µF

R1=2.7k ~ 3.3k

Don't input on-sig until the provided (R1 × Crev(s)) time has been exceeded after supplied power to this hybrid IC.

APPLICATION EXAMPLE OF HIGH POWER MODULE

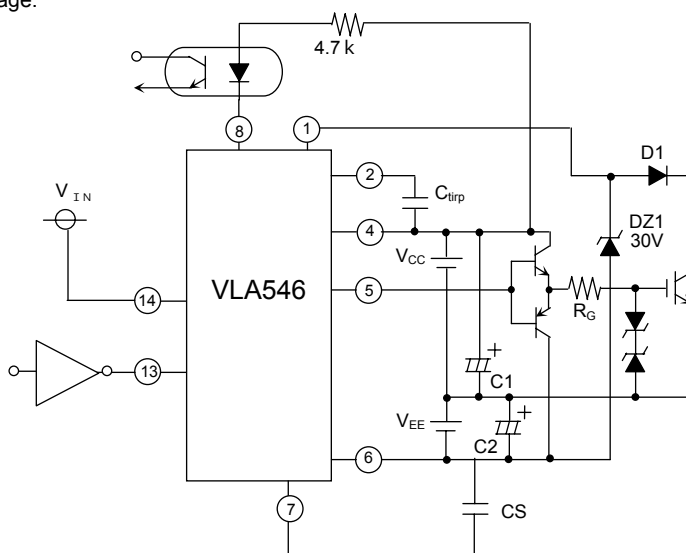
 $V_{CC} = 15V$ $V_{EE} = 10V$

Ctrip=10pF

C1,C2 100µF(low impedance)

FOR SAFETY USING

Great detail and careful attention are given to the production activity of Hics, such as the development, the quality of production, and in its reliability. However the reliability of Hics depends not only on their own factors but also in their condition of usage. When handling Hics, please note the following cautions.

CAUTIONS	
Packing	<p>The materials used in packing Hics can only withstand normal external conditions.</p> <p>When exposed to outside shocks, rain and certain environmental contaminators, the packing materials will deteriorates. Please take care in handling.</p>
Carrying	<ol style="list-style-type: none"> 1) Don't stack boxes too high. Avoid placing heavy materials on boxes. 2) Boxes must be positioned correctly during transportation to avoid breakage. 3) Don't throw or drop boxes. 4) Keep boxes dry. Avoid rain or snow. 5) Minimal vibration and shock during transportation is desirable.
Storage	<p>When storing Hics, please observe the following notices or possible deterioration of their electrical characteristics, risk of solder ability, and external damage may occur.</p> <ol style="list-style-type: none"> 1) Devices must be stored where fluctuation of temperature and humidity is minimal, and must not be exposed to direct sunlight. Store at the normal temperature of 5 to 30 degrees Celsius with humidity at 40 to 60%. 2) Avoid locations where corrosive gasses are generated or where much dust accumulates. 3) Storage cases must be static proof. 4) Avoid putting weight on boxes.
Extended storage	<p>When extended storage is necessary, Hics must be kept non-processed. When using Hics which have been stored for more than one year or under severe conditions, be sure to check that the exterior is free from flaw and other damages.</p>
Maximum ratings	<p>To prevent any electrical damages, use Hics within the maximum ratings. The temperature, current, voltage, etc. must not exceed these conditions.</p>
Polarity	<p>To protect Hics from destruction and deterioration due to wrong insertion, make sure of polarity in inserting leads into the board holes, conforming to the external view for the terminal arrangement.</p>

**Keep safety first in your circuit designs!**

·ISAHAYA Electronics Corporation puts the maximum effort into making semiconductor products better and more reliable, but there is always the possibility that trouble may occur with them. Trouble with semiconductors may lead to personal injury, fire or property damage. Remember to give due consideration to safety when making your circuit designs, with appropriate measures such as (1) placement of substitutive, auxiliary, (2) use of non-flammable material or (3) prevention against any malfunction or mishap.

Notes regarding these materials

- These materials are intended as a reference to our customers in the selection of the ISAHAYA products best suited to the customer's application; they don't convey any license under any intellectual property rights, or any other rights, belonging ISAHAYA or third party.
- ISAHAYA Electronics Corporation assumes no responsibility for any damage, or infringement of any third party's rights, originating in the use of any product data, diagrams, charts or circuit application examples contained in these materials.
- All information contained in these materials, including product data, diagrams and charts, represent information on products at the time of publication of these materials, and are subject to change by ISAHAYA Electronics Corporation without notice due to product improvements or other reasons. It is therefore recommended that customers contact ISAHAYA Electronics Corporation or an authorized ISAHAYA products distributor for the latest product information before purchasing product listed herein.
- ISAHAYA Electronics Corporation products are not designed or manufactured for use in a device or system that is used under circumstances in which human life is potentially at stake. Please contact ISAHAYA electronics corporation or an authorized ISAHAYA products distributor when considering the use of a product contained herein for any specific purposes, such as apparatus or systems for transportation, vehicular, medical, aerospace, nuclear, or undersea repeater use.
- The prior written approval of ISAHAYA Electronics Corporation is necessary to reprint or reproduce in whole or in part these materials.
- If these products or technologies are subject to the Japanese export control restrictions, they must be exported under a license from the Japanese government and cannot be imported into a country other than the approved destination. Any diversion or re-export contrary to the export control laws and regulations of Japan and/or the country of destination is prohibited.
- Please contact ISAHAYA Electronics Corporation or authorized ISAHAYA products distributor for further details on these materials or the products contained therein.