

# DigiPyro<sup>®</sup> Family

## PYD 1998, PYD 1988, PYD 1978

How to use Dual Element DigiPyro<sup>®</sup>  
Basics - Application - Advantages

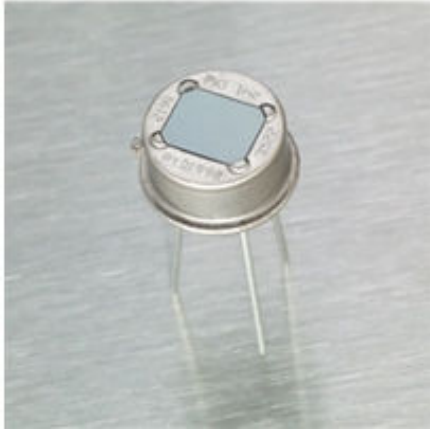

### Introduction

All motion detection applications are employing pyroelectric infrared detectors. Most units have traditionally been designed around dual element configurations. Pyroelectric detectors are AC-type devices and give signals upon a change of received infrared (IR) radiation. Until today, all available detectors were analog, i.e. they provide an analog signal output. Excelitas now introduces the first detector series that, unlike previous generations, offers a digital signal output.

### Features and Benefits

- ▶ Digital output sensor 15-bit output "Direct Link" 3-pin TO-5 housing
- ▶ Dual element design
- ▶ 2 x 1 mm<sup>2</sup> elements
- ▶ 1 mm spacing
- ▶ Infrared window
- ▶ 5.5..14 μm transmission
- ▶ Window size: PYD 1998 5.2 x 4.2 mm<sup>2</sup>  
PYD 1988 4,6 x 3,4 mm<sup>2</sup>  
PYD 1978 4,0 x 3,0 mm<sup>2</sup>
- ▶ High-level electrical performance
- ▶ Low EMI sensitivity
- ▶ Unique responsivity

### Applications

- ▶ Intrusion alarm applications
- ▶ Motion-activated light switches
- ▶ Door openers

### Authors

Hartmut Jesch,  
Gerhard Knaup,  
Thomas Kastner  
Harald Thomas

Excelitas Technologies  
Wenzel-Jaksch-Str. 31  
65199 Wiesbaden, Germany

Phone: +49 611 492 247  
Fax: +49 611 492 170

generalinquiries@excelitas.com

# Table of Contents

<b>1</b>	<b>Definitions .....</b>	<b>3</b>
<b>2</b>	<b>Electrical Configuration.....</b>	<b>3</b>
2.1	From Analog to Digital .....	3
2.2	The Digital Zero Signal Line.....	3
2.3	Out of Range Feature.....	4
2.4	Data Communication .....	4
2.5	Interrupt Driven Read Out.....	5
2.6	Electrical Data .....	7
2.7	Typical Responsivity vs. Frequency.....	8
<b>3</b>	<b>Software Filter Recommendation.....</b>	<b>8</b>
<b>4</b>	<b>Typical Application Circuit .....</b>	<b>9</b>
<b>5</b>	<b>Operating and Handling .....</b>	<b>9</b>
5.1	Handling.....	9
5.2	Soldering Conditions .....	9
5.3	Product Safety & RoHS .....	10
5.4	Performance Advice .....	10
<b>6</b>	<b>Frequently Asked Questions.....</b>	<b>11</b>

## List of Figures

Figure 1	Block diagram of DigiPyro®.....	3
Figure 2	DigiPyro® connections .....	4
Figure 3	ADC and data transmission diagram (transmitted value: 146 D <sub>Hex</sub> = 5299 <sub>Dez</sub> ).....	4
Figure 4	DigiPyro® read-out flow chart .....	5
Figure 5	Frequency response .....	8
Fig.6	Typical application circuit.....	9

## List of Tables

Table 1	DigiPyro® electrical data .....	7
---------	---------------------------------	---

## 1 Definitions

**Element:** This is a sensing surface with a defined size. As all units work with optics, this element and the optics will determine the performance.

**Channel:** This refers to an individual detector. When there are two channels, there are also two individual detectors or two individual outputs.

**Detector / Sensor:** A detector gives a pure output signal; the sensor has a processed signal output.

**Direct link interface:** The *direct link* is the interface between DigiPyro® and any micro controller. It is a bidirectional single wire connection specially designed for this application.

**Data Rate:** The refresh time of data (availability of new data block).

**Resolution:** The analog value of one bit.

**Clock Time:** This refers to the  $n \times (1 / \text{internal clock frequency (the frequency of internal command processing)})$ .

## 2 Electrical Configuration

The DigiPyro® consists of a dual element configuration that is connected to a special integrated circuit. It contains the analog-to-digital converter that generates a 15-bit serial signal, a second-order digital low-pass filter, an on-chip low-power oscillator, and a serial interface. The functional block diagram is shown below.

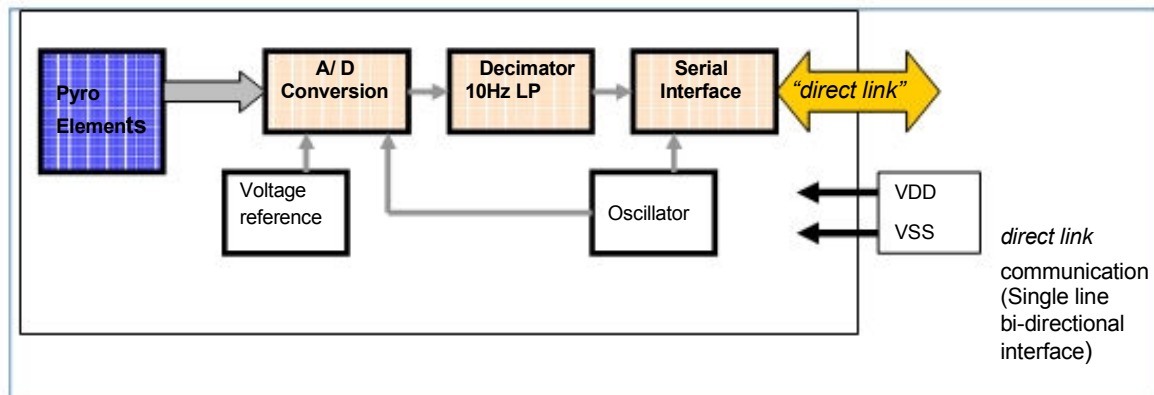

Figure 1 Block diagram of DigiPyro®

### 2.1 From Analog to Digital

The DigiPyro® is the first Pyroelectric detector to display information in “bit” as compared to mV signals of analog detectors. For engineers traditionally laying out systems in respect to analog signals, the following rough comparison may be helpful:

- Resolution: 1 bit  $\triangleq$  6.5  $\mu$ V
- Range: 0 to 16383 bit  $\triangleq$   $\pm$  53.6 mV
- DC offset 8250 bit  $\triangleq$  53.6 mV typical
- Noise: 3 bit  $\triangleq$  19.5  $\mu$ V (with band-pass)

### 2.2 The Digital Zero Signal Line

Since the pyroelectric effect generates positive and negative signal amplitudes, the detector circuitry needs an electrical offset to process the signals. The internal voltage reference provides this offset. To the user, this offset appears as a digital zero line ranging at 8250 bit and may differ in series from one part to the next. To recognize the zero line of the individual detector, the user may use either a

digital band-pass or subtract the measured offset from the signal. To do so, the detector must be covered from incidental radiation and protected from possible air drafts and indirect radiations. The detector output is then monitored. The resulting signal represents the individual zero line. Once the reading is stabilized, this value can be taken and stored in the user's  $\mu$ Processor as the detector's zero line. The same feature is provided by Excelitas' application kit for the DigiPyro<sup>®</sup>.

### 2.3 Out of Range Feature

To avoid detector saturation, the DigiPyro<sup>®</sup> includes a special out-of-range detection feature. It shows when the detector runs into saturation caused by temperature shock, which can result from touching the detector with warm hands. This special feature of the digital detectors shortens the input of the circuit for a duration of 512 system clocks as it monitors the digital values rising above 15872 bit or falling below 511 bit. If this re-occurs, the input is shortened repeatedly until the thermal shock problem has expired.

### 2.4 Data Communication

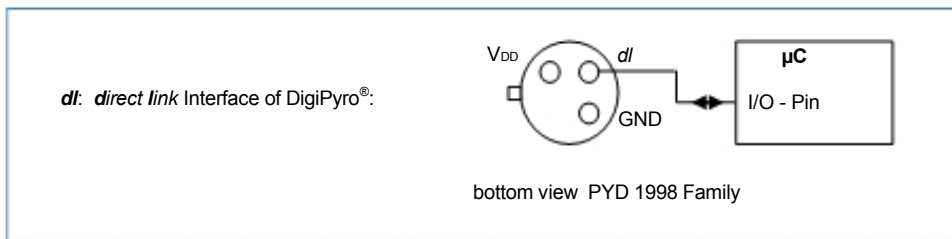

Figure 2 DigiPyro<sup>®</sup> connections

The serial interface has a 15-bit binary output format that allows a physical data value range from 0 to 32767. However, due to the ADC **resolution of 14 bit**, the most significant bit (MSB) is always LOW and, thus, the **data range is limited to values from 0 to 16383**. The *direct link* pin is used as bi-directional data output and clock input.

The following diagram shows the communication signal flow:

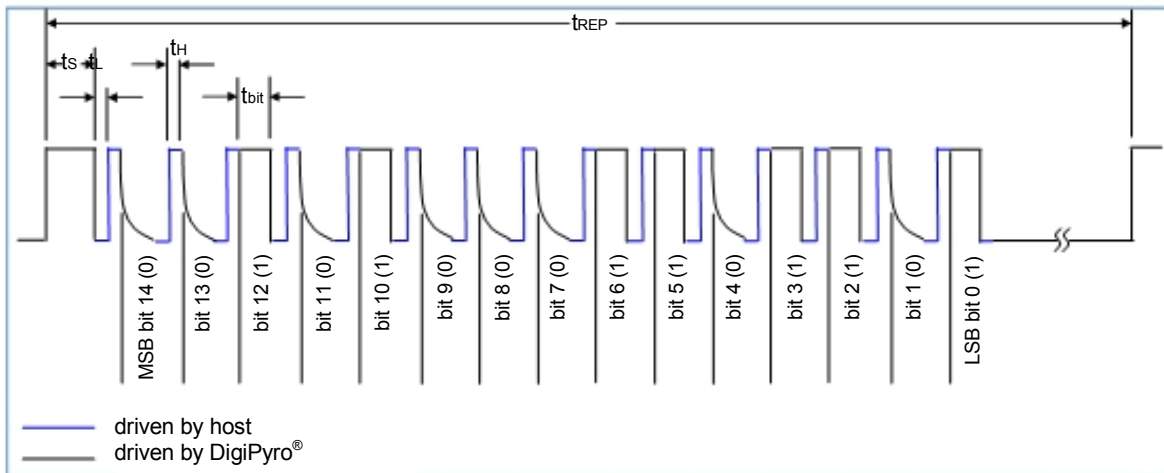

Figure 3 ADC and data transmission diagram (transmitted value: 146 D<sub>Hex</sub> = 5299<sub>Dez</sub>)

A data block transmission cycle (refresh time  $t_{REP}$ ) starts when the circuit has converted a new data value and passed it through the LP filter to the serial interface. The **start of transmission is indicated from the DigiPyro<sup>®</sup> by pulling the direct link pin to HIGH**.

After the setup time ( $t_s$ ) has passed, the DigiPyro<sup>®</sup> expects a LOW to HIGH transition ( $t_L$ ,  $t_H$ ) on the *direct link* pin and will subsequently output the data bit state. After the data bit settling time ( $t_{bit}$ ), the DigiPyro<sup>®</sup>

waits for the next LOW to HIGH transition and the sequence is repeated until all 15 bits have been shifted out. After the output of the last bit (bit 0) and the corresponding data bit settling time ( $t_{bit}$ ), the host controller forces the *direct link* pin to LOW and subsequently releases the *direct link*. The DigiPyro<sup>®</sup> remains with the *direct link* pin at LOW level until the next signal sample is available at the serial interface and a new transmission cycle starts.

The data bit settling time  $t_{bit}$  specified under electrical data is a minimum time. For the LOW level, it can vary depending on the capacitive load of the *direct link* pin. It is recommended to start host interface implementation with a longer data bit settling time  $t_{bit}$  to ensure proper LOW level settling, reducing  $t_{bit}$  empirically to optimize reliable data transmission at maximum transmission speed.

If data transmission is interrupted during data clock low time ( $t_L$ ), the serial interface is updated with a new value, provided  $t_L$  lasts longer than the serial interface update time ( $t_{REP}$ ), which can cause a false reading if the data transmission is continued. Therefore data transmission should preferably be interrupted during data clock high time ( $t_H$ ). If interruption lasts longer than the serial interface update time ( $t_{REP}$ ), the serial interface will not be updated with new values.

If a host reads the serial interface output faster than the update rate of the serial interface ( $t_{REP}$ ), the data bits are all read LOW.

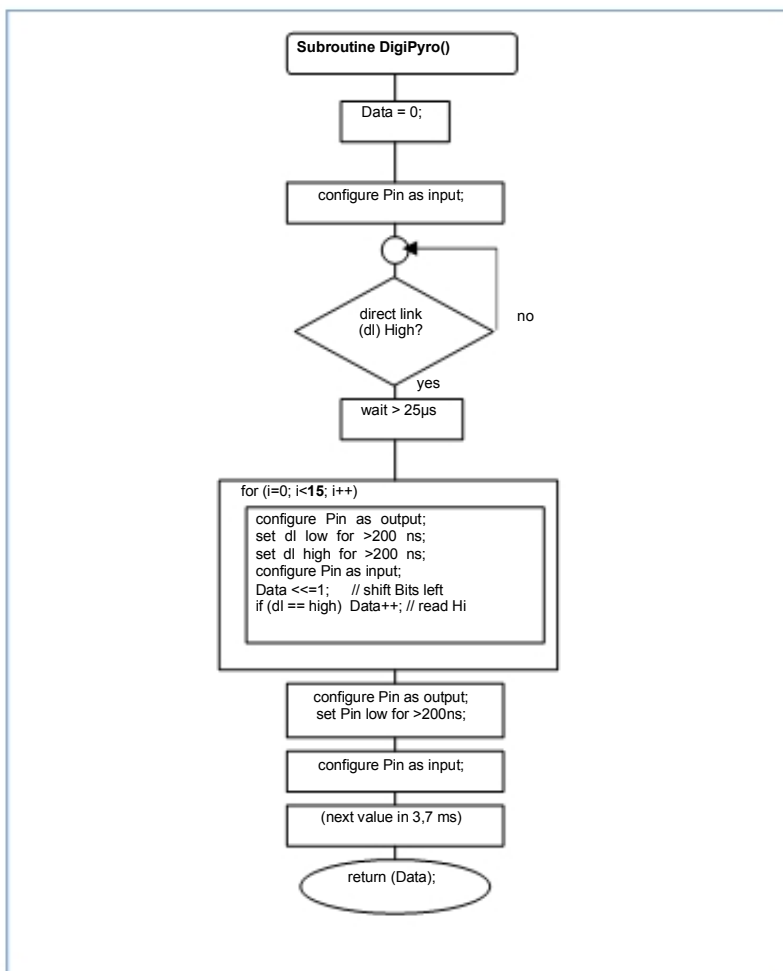

Figure 4 DigiPyro<sup>®</sup> read-out flow chart

## 2.5 Interrupt Driven Read Out

To transfer the above read-out flow chart into a software code, a simple program code in C-language can be applied. (Program code for Atmel<sup>®</sup> ATmega 8  $\mu$ C - as I/O- pin port C Bit 0 is used).

```

// DL: Direct Link Interface of the Dual Element DigiPyro®. A bidirectional single wire interface, //
directly connectable to most µC's I/O- pins.
// V2.03 10.12.2007 read the Dual Element DigiPyro® synchronous
// µC: Atmel® ATmega8, 6MHz: Port C0 (ADC0, Pin 23) connected to Int0 (Pin 32) external Interrupt. //
DPDL High will cause an Interrupt and so start reading the Dual Element DigiPyro®
// immediately when ADC has finished
// read 15 Bits from Dual Element DigiPyro®

#include <mega8.h>

// Definitions for DigiPyro® Port C Bit 0
#define DDPDL      DDRC.0    // port C bit 0 data direction bit
#define DPDL_OUT   PORTC.0   // port C bit 0 output
#define DPDL_IN    PINC.0    // port C bit 0 input
#define PORT_IS_INP 0
#define PORT_IS_OUTP 1

int PIR_Data;           // Signal

// *** *
// External Interrupt 0 service routine
//
// read DigiPyro®
//
interrupt [EXT_INT0] void ext_int0_isr(void)

{
    // Disable External Interrupt0 until DigiPyro® is read.
    MCUCR &= 0xFC;           // Ext. Interrupt 0 disabled while reading
    digipyro();
    MCUCR |= 0x03;           // Ext. Interrupt 0 enabled
}

// *** *
// function: digipyro()
//
// do not read asynchronous to the ADC- converter. Read the interface interrupt-driven: High = new data //
this routine should preferably be used by the interrupt routine only.
// use PIR_Data for access to the DigiPyro® after interrupt

int digipyro(void)
{
    int i, j;

    PIR_Data = 0;
    DDPDL = PORT_IS_INP;     // Configure PORT C0 as Input for
                             // DigiPyro® Direct Link Interface (DPDL)

    while(DPDL_IN == 0);     // wait for DPDL = high - max. 1 ms (in regular mode)
    for(j=0; j < 60; j++);   // wait appr. 30 µsec (tS)

    for(i=0; i < 15; i++)    // 15 Bits, MSB is low
    {
        DPDL_OUT = 0;       // Set DPDL = Low, Low level duration must be > 200 ns (tL)
        DDPDL = PORT_IS_OUTP; // Configure PORT C0 DPDL as Output
        DPDL_OUT = 0;       // Set DPDL = Low, Low level duration must be > 200 ns (tL)
        #asm("nop")
        DPDL_OUT = 1;       // Set DPDL = High, High level duration must be > 200 ns (tH)
        #asm("nop")
        DDPDL = PORT_IS_INP; // Configure PORT C0 DPDL as Input

        for(j=0; j < 2; j++); // wait appr. 5 µsec to ensure proper low level reading (tbit)
        PIR_Data <<= 1;
        if (DPDL_IN) PIR_Data++; // sample bit
    }
    DDPDL = PORT_IS_OUTP;   // Configure PORT C0 DPDL as Output
    DPDL_OUT = 0;           // Set DPDL = Low, Low level duration must be > 200 ns (tL)
    DDPDL = PORT_IS_INP;   // Configure PORT C0 DPDL as Input
    return (PIR_Data);
}

void main(void)

{
    // Port C initialization
    // Func6=In Func5=Out Func4=Out Func3=Out Func2=Out Func1=In Func0=In
    // State6=T State5=0 State4=0 State3=0 State2=0 State1=T State0=T
    PORTC = 0x00;
    DDRC = 0x3C;
}

```

```

// External Interrupt initialization
// INT0: On
// INT0 Mode: Rising Edge, DigiPyro® triggers Interrupt to be immediately read after conversion
GICR   |= 0x40;
MCUCR &= 0xFC;
GIFR   |= 0x40;

SFIOR  |= 0x04;                // no pullups: PUD=1 (Bit#2)

#asm("sei")                    // Global enable interrupts
// .. your code ..
channel0 = PIR_Data;
}

```

## 2.6 Electrical Data

Below is all required data to operate the detector. Unless specified differently, all data refers to 25°C environmental temperature.

Parameter	Symbol	Min	Typ	Max	Unit	Remarks
Operating Voltage	V <sub>DD</sub>	3.0	5.0	5.5	V	
Supply Current	I <sub>DD</sub>		30	40	µA	V <sub>DD</sub> = 5 V
Input Low Voltage	V <sub>IL</sub>			0.2V <sub>DD</sub>	V	
Input High Voltage	V <sub>IH</sub>	0.8 V <sub>DD</sub>			V	
Pull Up / Down Current		220	280	350	µA	Input to V <sub>SS</sub> / V <sub>DD</sub>
Input Capacitance			5		pF	
Data Setup Time	t <sub>s</sub>	25			µs	
Data Clock Low Time	t <sub>L</sub>	200			ns	
Data Clock High Time	t <sub>H</sub>	200			ns	
Data Bit Settling Time	t <sub>bit</sub>	1			µs	C <sub>LOAD</sub> = 10 pF
Serial Interface Refresh Time	t <sub>REP</sub>		3.7		ms	
Serial Interface Refresh Frequency	f <sub>REP</sub>		273		Hz	
ADC Counts of Bits			15		Bits	1 <sup>st</sup> Bit is "0"
ADC Resolution			14		Bits	Max Count = 2 <sup>14</sup>
ADC Sensitivity		6.1	6.5	7	µV/count	
ADC Offset		6200	8250	11000	Bit	
Responsivity <sup>1)</sup>		3.3	4.0		kV/W	
Match <sup>2)</sup>				10	%	
Noise <sup>3)</sup>			20	50	µVpp	
LPF Cut-Off Frequency			10		Hz	
Internal Clock Frequency	f <sub>CLK</sub>	60	70	90	kHz	
Operating Temperature	T <sub>o</sub>	-40		85	°C	The electrical parameters may vary from specified values accordance with their temperature dependence.
Storage Temperature	T <sub>s</sub>	-40		85	°C	Avoid storage under high humid environment.

Table 1 DigiPyro® electrical data

<sup>1)</sup> Responsivity is measured within spectral range 7 - 14 µm as per fig. 3 at 1 Hz.

2) Electrical balance (match) is measured with same test set up as responsivity, both elements exposed to radiation. A percent value is calculated as

$$\frac{100 \times S_m}{S} \quad S_m : \text{signal (match), } s: \text{signal of left or right element.}$$

3) After a 10-minute settling time, noise is monitored for the duration of 1500 sec. at a temperature of 5°C, shut from infrared energy, digital filter between 0.4 to 10Hz.

## 2.7 Typical Responsivity vs. Frequency

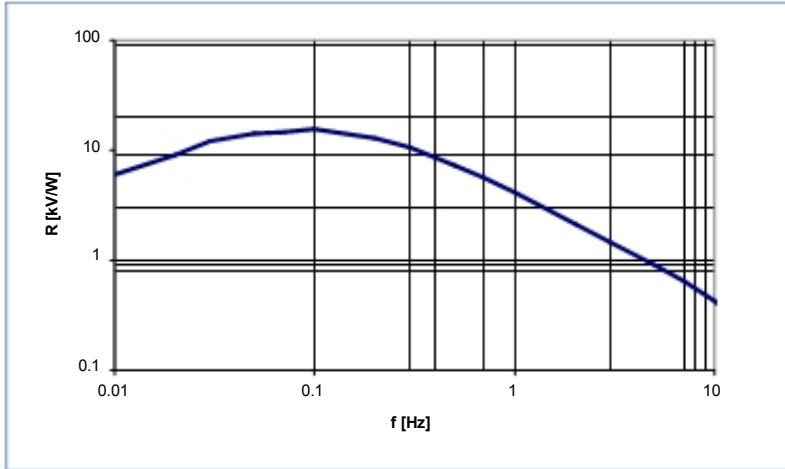

Figure 5 Frequency response

## 3 Software Filter Recommendation

The most unique feature of DigiPyro® is the direct communication with the hosting microcontroller without requiring any hardware filtering. Thus, it is recommended that software filters be implemented within the host.

Various websites give recommendations for software designed filters. You may also check at:

<http://www-users.cs.york.ac.uk/~fisher/mkfilter/>

[http://www.atmel.com/dyn/resources/prod\\_documents/doc2527.pdf](http://www.atmel.com/dyn/resources/prod_documents/doc2527.pdf)

Please note: The links above are to external websites and beyond Excelitas' control or responsibility. For that reason, Excelitas does not guarantee the accuracy of the content or any functions provided by these links.



## 4 Typical Application Circuit

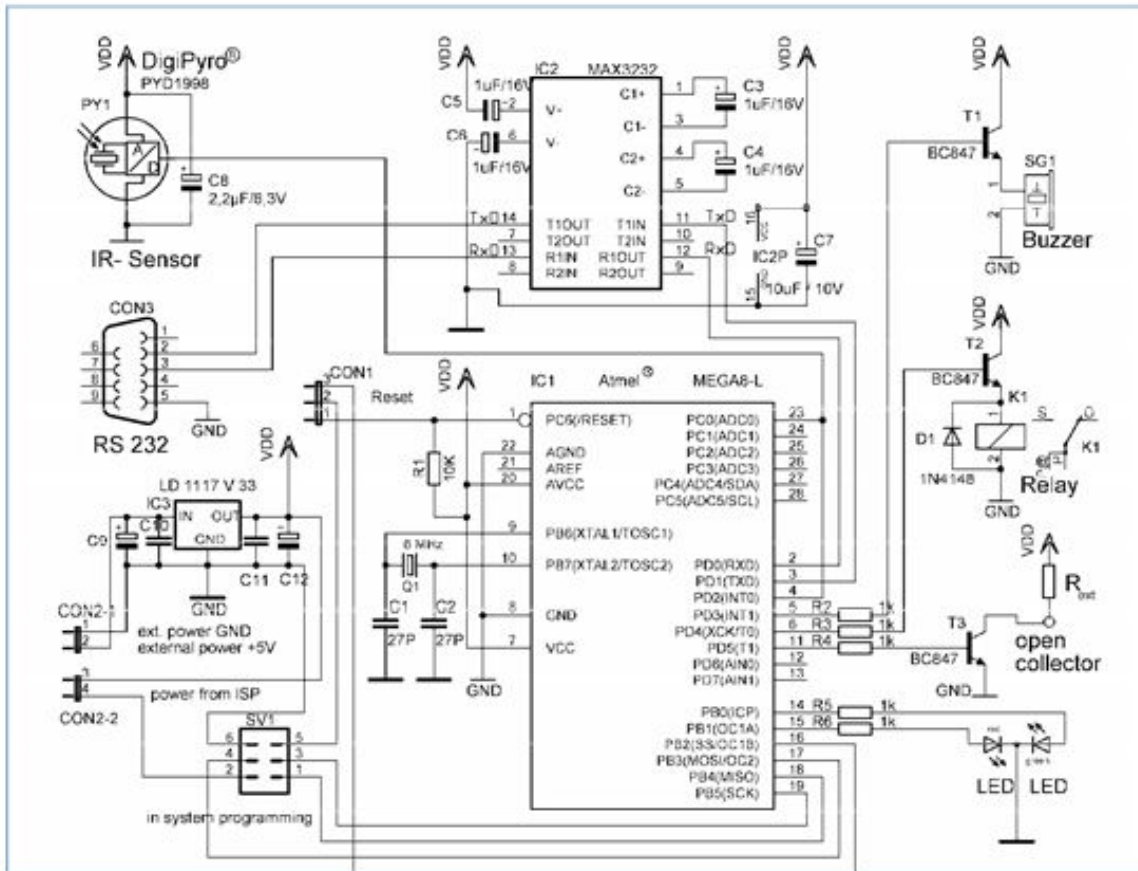

Fig.6 Typical application circuit

The above circuit shows possible applications for DigiPyro® as an alarm with buzzer or LED output and as a light switch with relay output or general purpose open collector output. It uses PYD 1998 Family with Atmel® processor Mega8-L and 3.3 V voltage stabilization. In addition, RS232 communication interface is provided. The voltage supply to DigiPyro® is buffered by a 2.2  $\mu$ F capacitor (C8).

## 5 Operating and Handling

### 5.1 Handling

Handle the detectors as ESD sensitive devices and protect them from electrostatic discharges. Working areas should be conductive and grounded. When handling detectors, operators must be grounded. Avoid mechanical stress on the housing and especially on the leads. Be careful when cutting or bending leads to avoid damage. Do not bend leads less than 5 mm from their base. Do not drop detectors on the floor. Avoid touching the detector window. To clean windows when necessary, use only ethyl alcohol with a cotton swab. Do not expose detectors to aggressive detergents such as Freon, Trichloroethylene, etc.

### 5.2 Soldering Conditions

For soldering the detectors within PCBs, the typically applied and recommended process is wave soldering. The soldering temperature should not exceed 285° C with a maximum exposure time of five seconds. During the automatic wave solder process, we strongly advise restricting preheating when the detector is directly exposed to the radiation of such heaters. In this case, the detector should be protected from the heat.

Manual soldering is also possible when maintaining similar temperature profiles. Reflow soldering is not possible due to the high temperature profiles of the process.

### 5.3 Product Safety & RoHS

Modern high-tech materials are applied in the production of our Pyroelectric detectors. Some of these materials are sensitive to high temperature exposure or to specific forms of stress. Our parts are compliant with environmental regulations that may be reviewed on the Excelitas website. We recommend always checking your local regulations. Disposal should only be carried out in accordance with the latest legislation and directives. In Europe, WEEE directives must be followed.

The leads of these detectors have been pre-tinned with lead-free tin processes and may be applied through lead-free solder processes. As such, these detectors enable the design of RoHS compliant products.

### 5.4 Performance Advice

Before taking a reading during testing, and/or operation, the unit must become thermally stable due to its nature as a thermal detector and the high sensitivity of the device.

All data are specified at room temperature. When operating at other temperatures within the specified operating range, parameters may vary. The detector might operate outside the quoted range, but may exhibit degraded performance.

## 6 Frequently Asked Questions

1. **What is the data rate?**  
273 Hz typical.
2. **What is the signal range?**  
Theoretically 0 to 16383 bit in the application, depending on the optical system.
3. **Why do I have 8100 digit outputs with no radiation?**  
Digital offset / working point.
4. **How often will the Master need to request a signal package? Is a 25 Hz sampling rate suitable?**  
The Master may repetitive request up to 230 times / sec - one request = 1 package.  
25 Hz may be insufficient. Recommended value is 80.
5. **Will I need signal filtering?**  
Yes: proposed digital BPF 0.2 Hz to 10 Hz.
6. **Does the DigiPyro® offer any cost saving advantages?**  
Yes, less component requirements, PCB space, and assembly work will result in lower system costs.
7. **What is power supply requirement?**  
Minimum voltage requirement is 3.0 Volts, maximum supply current is 40  $\mu$ A. As for any digital device, the switching of the gate array may cause current peaks. Thus, a buffering capacitor of 2.2  $\mu$ F is recommended.
8. **What are the advantages of DigiPyro® compared to analogue version?**  
Better supply voltage rejection of disturbances, no analog signal processing, and no RF interference problems. User defines signal processing, filtering, threshold detection and / or envelope evaluation. Higher reliability for the complete system.
9. **After power is applied how long before accurate readings can be obtained from the device?**
  - a) The internal A/D- converter needs  $t_{REP} = 3.7$  ms to convert a value.
  - b) The detector has to reach thermal equilibrium with the environment. This can take a few seconds to achieve accurate readings, which is typical for all thermal sensors.
10. **There appears to be a maximum rate but no minimum rate for Master reads.**  
Yes, there is no minimum read rate.
11. **What is the sampling rate?**  
Sampling rate is determined by the hosting  $\mu$ C and can be up to the specified refresh time of 1/230 Hz.
12. **Why does it offer 15-bit output?**  
The high resolution of 14-bit allows for accurate signal processing across the entire dynamic range. One additional bit is required for control purposes.
13. **Why is the output not at zero, when there is no radiation?**  
The pyro elements provide positive and negative signals. For that reason, the base line is set to the mid value of the dynamic range (approx. 8200 bit). This digital offset represents the zero line.
14. **What is the content of a data package?**  
A package consists of a 'data word ready' signal (= high). After detecting this signal, the microcontroller has to wait for min. 30  $\mu$ s setup time. The microcontroller then reads 15 bits. Data arrives with MSB first. The first bit can be discarded. The reading procedure is defined at 2.4 data communication.
15. **How do I handle interrupts, without corrupting data?**  
The sensor only updates the data in the direct link interface, while it is at low level for more than 96 to 128 system clock cycles. There is no update if *direct link* line is kept at high level.  
If the controller has to serve an Interrupt, set the *direct link* line "high" for the duration of the interrupt. When coming out of the interrupt routine, release it and read the value/bit. Continue reading as normal.
16. **Output of the sensor: Is there a need for pull-up or may the sensor directly be hooked to the computer pin?**  
The DigiPyro® can be hooked directly to a digital I/O- pin of a microcontroller (for example an Atmel® Mega8). But the  $\mu$ C must be able to drive the pin to High and Low. With some  $\mu$ C's it

- might be necessary to have a pull-up resistor in the 20 k $\Omega$  range, if the  $\mu$ C has problems to push the pin to High (the DigiPyro<sup>®</sup> input current is typ. 280  $\mu$ A).
17. **How to read the data output of PYD 1998 Family by using a  $\mu$ C I/O port?**  
It should not be a problem to use a I/O- pin directly (e.g. Atmel<sup>®</sup> Mega 8  $\mu$ C).  
The typical push/pull- current of the DigiPyro<sup>®</sup> is 280  $\mu$ A (220  $\mu$ A - 350  $\mu$ A). This is enough for  $\mu$ C- input- impedance higher than 10 kOhms. Please check the output voltage with an oscilloscope. Does the voltage drop to Low too? If the DigiPyro<sup>®</sup> cannot produce a High, a pullup-resistor in the 20 kOhm- range will help. But most likely it is a communication problem/timing problem rather than a problem with the voltage levels.
18. **Why should I read the the data from the Dual Element DigiPyro<sup>®</sup> interrupt driven?**  
To fully benefit from the low noise performance of the device, we recommend to read the Triple Channel DigiPyro<sup>®</sup> synchronous as soon as the ADC has finished a conversion. The easiest way to do this is to call the readout routine from an interrupt routine. Therefore the input of the  $\mu$ Processor should be connected to an interrupt line too.  
A raising slope on the *DIRECT LINK* interface should be used to trigger the interrupt. The interrupt line has to be disabled then while reading the data.
19. **Summary: The procedure to read the data from the DigiPyro<sup>®</sup>**
1. You should first wait for the detector pulling the Direct Link interface high.
  2. Then wait for 25  $\mu$ s.
  3. Drive the line low for at least  $t_L = 200$  ns then pull it high for at least  $t_H = 200$  ns, then release it to read (high ohmic).
  4. Then the detector will give the first bit (MSB) to the output.
  5. Depending on your input capacitance, you have to wait with reading until there is a saturation of the output (otherwise you will read a high):150
  6. Wait for at least  $t_{bit} = 1\mu$ s (for 10 pF on your input line, for higher C wait longer) to allow the line to discharge your input capacitor.
  7. Read the bit.
  8. Repeat this (step 3 to 8) until all 15 data bits (single) are read.
  9. Then drive it low for at least  $t_L = 200$  ns, then release it (high ohmic).
  10. After the conversion time of the ADC  $t_{REP} = 512$  clock cycles (3.7 ms for Single) wait for the detector pulling the direct link interface high (step 1) and read the next value by repeating this procedure (steps 1 to 9) from the start.

Note: the first bit (MSB) of a single channel DigiPyro<sup>®</sup> is a low ("0").

**North America Customer Support Hub**  
**Excelitas Technologies**  
 22001 Dumberry Road  
 Vaudreuil-Dorion, Québec  
 Canada J7V 8P7  
 Telephone: +1 450-424-3300,  
 (+1) 866-574-6786 (toll-free)  
 Fax: +1 450-424-3345  
 generalinquiries @excelitas.com

**European Headquarters**  
**Excelitas Technologies**  
 Wenzel-Jaksch-Str. 31  
 65199 Wiesbaden, Germany  
 Telephone: (+49) 611-492-247  
 Fax: (+49) 611-492-170

**Asia Headquarters**  
**Excelitas Technologies**  
 47 Ayer Rajah Crescent #06-12  
 Singapore 139947  
 Telephone: (+65) 6775-2022  
 Fax: (+65) 6775-1008

**EXCELITAS**  
 TECHNOLOGIES

For a complete listing of our global offices, visit [www.excelitas.com](http://www.excelitas.com)

©2011 Excelitas Technologies Corp. All rights reserved. The Excelitas logo and design are registered trademarks of Excelitas Technologies Corp. DigiPyro<sup>®</sup> is a trademark of Excelitas Technologies Corp. or its subsidiaries, in the United States and other countries. All other trademarks not owned by Excelitas Technologies or its subsidiaries that are depicted herein are the property of their respective owners. Excelitas reserves the right to change this document at any time without notice and disclaims liability for editorial, pictorial or typographical errors.  
 600249\_01 APP0208